

1. Technische Daten und bildliche Darstellung
1. Technical data and pictorial representation

Anschlußspannung	230V/50Hz
Leistungsaufnahme in Watt	240
Kompressorleistung in Watt (PS)*	262 (1/6)
Kältemittel R 134 a in kg	0,100

Supply voltage	
Power consumption in watt	
Compressor output in watt (hp)*	
Refrigerant R 134 a in kg	

Konstante Kühlleistung bei 4°C Wasserbad	
in Watt	230
in kcal/h	197
Eisbankgewicht in kg	/

Konstant cooling capacity at 4°C watherbath	
in watt	
in kcal/h	
Weight of ice bank in kg	

Wasserbadinhalt in Liter	10
--------------------------	----

Waterbath capacity in liter	
-----------------------------	--

Abmessungen in mm	
Höhe	400
Breite	445
Tiefe	320
Gerätgewicht in kg	18,5

Dimensions in mm	
Height	
Width	
Depth	
Unit weight in kg	

* bei -0°C Verdampfungstemperatur

* at -0°C evaporation temperature

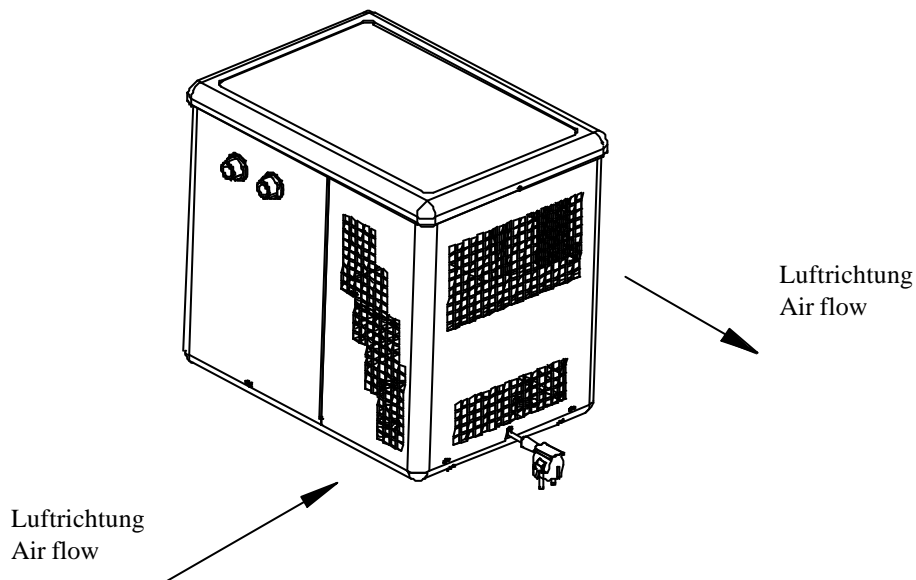

2. Stromlaufplan

2. Circuit diagram

- C1 Anlaufkondensator
- C2 Anlaufkondensator Rührwerk
- F1 Regler (mechanisch)
- F2 Thermoschutz
- K1 Startrelais
- M1 Rührwerkmotor
- M2 Kompressor
- M3 Ventilator
- R1 Temperaturfühler (mechanisch)
- X1 Stecker Rührwerkmotor

- C1 Start capacitor
- C2 Start capacitor agitator
- F1 Control board
- F2 Tempr. protection
- K1 Start relay
- M1 Agitator
- M2 Compressor
- M3 Fan motor
- R1 Probe
- X1 Plug agitator motor

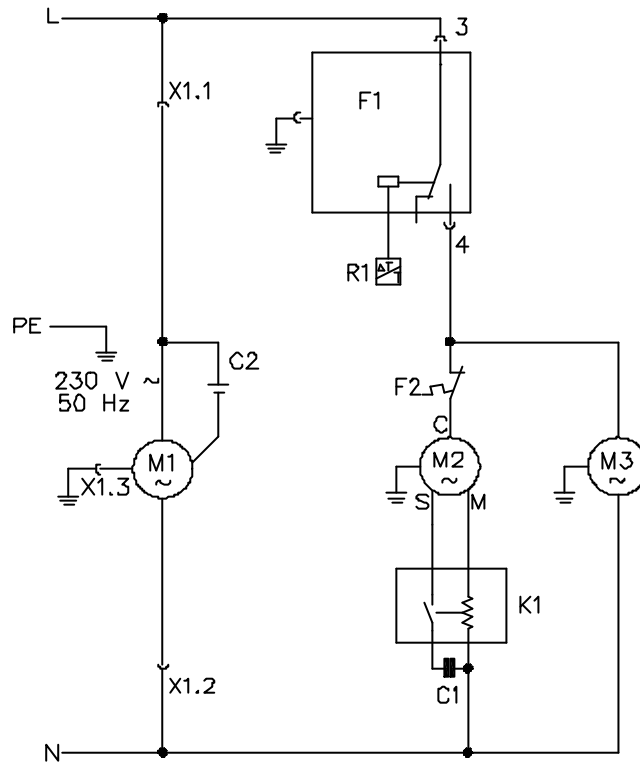

2. Position des Temperaturfühlers

2. Position of the probe

